

ROJ
MECHATRONICS

PCS W1



PCS W1

Installation
Operation
Maintenance

ORIGINAL INSTRUCTIONS

PCS W1 – Rev. 1.6 – October 2018
Copyright - ROJ - All rights reserved.

This manual is intended for the users of **PCS W1 Kit**.

ROJ reserves the right to change at any time the contents of this manual, without notice.

For any technical or commercial problem, please contact your local ROJ dealer or call directly ROJ customer service center. We will be glad to meet your needs.

Thank you for your trust and good job.

The PCS W1 Kit is patent covered and implements unique and highly technological solutions.

PCS W1

INSTALLATION, OPERATION AND MAINTENANCE MANUAL

Edition: *October 2018*
Revision: *1.6*

Direction and Plant:

ROJ

Via Vercellone 11

13900 Biella (BI)

Tel. +39 015 84 80 111

Fax +39 015 84 80 209

Email: comm@roj.com

www.roj.it

TABLE OF CONTENTS

INTRODUCTION..... iii

Safetyiv
 CE Identification Plateiv
 Compliance with the Directives and European Regulations v
 Warranty and Responsibility of the Manufacturervi
 Other warranty termsvi

1. GENERAL INFORMATION 1.1

1.1 INTRODUCTION..... 1.1
 1.1.1 The ideal solution for control and optimization for distributor control 1.1
 1.1.2 Manual objectives 1.1
 1.1.3 How to Use this Manual 1.1
 1.1.4 Symbols used..... 1.2
 1.1.5 Environment protection 1.2
 1.2 GENERAL INFORMATION AND PERFORMANCES 1.3
 1.2.1 Introduction 1.3
 1.2.2 Functional blocks 1.3
 1.2.3 Acronyms used 1.4
 1.3 COMPONENTS OF THE PCS W1 KIT 1.5
 1.4 GENERAL SAFETY INFORMATION 1.6
 1.4.1 Design Criteria 1.6
 1.4.2 Safety Devices and Solutions..... 1.7
 1.4.3 Warning About Residual Risks..... 1.8
 1.4.4 Warning and Rules of Behaviour for the Operator 1.8
 1.4.5 Noise Levels..... 1.9
 1.4.6 Radio frequency related information 1.9
 1.4.7 Proper and Improper Use..... 1.9
 1.4.8 Safety and reliability of control systems 1.10

2. INSTALLATION..... 2.1

2.1 GEARED MOTOR CHARACTERISTICS (PCS MD-O)..... 2.1
 2.1.1 Outlet shaft torque and speed 2.1
 2.1.2 Outlet shaft dimensions..... 2.1
 2.1.3 Fastening flange characteristics..... 2.2
 2.2 MOTOR INSTALLATION (PCS MD-O) 2.2
 2.2.1 General principles 2.2
 2.2.2 Mounting angle limits..... 2.2
 2.2.3 Transport cap 2.3
 2.2.4 Fastening 2.3
 2.3 SPEED SENSOR 2.4
 2.3.1 Cogwheel individual sensor..... 2.4
 2.4 MACHINE POSITION SENSOR 2.5
 2.4.1 Position sensor check 2.6
 2.5 AP POSITIONING 2.6
 2.6 ELECTRICAL CONNECTION DIAGRAM 2.7
 2.6.1 Main components 2.8
 2.6.2 MD connection 2.8

2.6.3	Safety switch	2.9
2.6.3	Safety switch	2.9
2.6.3	Safety switch	2.10
3.	USER MANUAL	3.1
3.1	GENERAL DESCRIPTION	3.1
3.2	CONNECTION TO ACCESS POINT	3.2
3.3	HOME PAGE	3.2
3.3.1	Connection and configuration buttons	3.3
3.3.2	Job information and settings	3.4
3.3.3	Alarm List	3.6
3.4	CONFIGURATION PAGE	3.7
3.4.1	Software Update	3.8
3.5	ALARMS	3.9
4.	MAINTENANCE AND TROUBLESHOOTING	4.1
4.1	GENERAL INSTRUCTIONS ABOUT MAINTENANCE WORKS	4.1
4.2	ORDINARY PREVENTIVE MAINTENANCE INTERVENTIONS IN CHARGE OF THE OPERATOR	4.1
4.3	MAINTENANCE / REPAIR RESERVED TO SPECIALIZED PERSONNEL	4.2
4.4	SPARE PARTS	4.3

INDEX UPDATES

04/07/2016	Rev. 1.1
20/12/2017	Rev. 1.2
12/01/2018	Rev. 1.3
08/02/2018	Rev. 1.4
22/03/2018	Rev. 1.5
08/10/2018	Rev. 1.6

INTRODUCTION

All machines ⁽¹⁾ and equipment designed and manufactured by **ROJ** are supplied with User and Maintenance Manuals prepared in compliance with the Essential Health and Safety Requirement (EHSR) 1.7.4 – *Instructions* – of Machinery Directive 2006/42/EC Annex 1.

As the prescriptions of Machinery Directive, and in particular the EHSRs of Annex 1 represent **mandatory law obligations**, in writing the manuals, **ROJ** paid particular attention to all the items of EHSR 1.7.4, in particular:

1. The **ROJ** user and maintenance manuals are supplied in the language of machine target country, within the European Union and, when necessary, an “Original language” copy of the manual is also provided.
2. The **ROJ** manuals always contain a “proforma” copy of the EC Declaration of Conformity (or a “proforma” copy of the Declaration of Incorporation of the “Partly completed machinery” for the relevant machine. These have just an indicative value, and they shall not be considered substitutive of the actual Declaration of Conformity Incorporation subscribed by the supplier, and delivered separately to the Customer.
3. The **ROJ** User and Maintenance Manuals contain the information deemed important and necessary by the Manufacturer in order to:
 - Understand the principle of operation of the machine ⁽¹⁾.
 - Carry out the handling/assembly/installation/connection operations under **Safety Condition**, taking into account the possible hazards connected with the above mentioned activities and providing the indications, prescriptions and suggestions resulting from a careful risk assessment performed by the Manufacturer following the principles of the Harmonized Standard EN 12100:2010 and of the Guide ISO/TR 14121-2.
 - Correctly use the machine in question (control devices, safety and emergency devices, operating procedures, etc.) under **Safety Conditions**, calling the operator attention on possible “Residual Risks”, i.e. the risks that remain notwithstanding all the safety measures adopted against the risk assessment performed, as indicated on the previous point.
 - Carry out the ordinary/preventive maintenance operations on the machine ⁽¹⁾ under **Safety Condition**, calling also in this case the maintenance technician attention on possible Residual Risks.
4. The **ROJ** User and Maintenance Manuals describe not only the intended used of the machine ⁽¹⁾, but also the reasonably expected misuses, according to the experience accrued by the Manufacturer.

SAFETY

ROJ, after the risk analysis and assessment carried out following the principles of Harmonized Standard EN 12100:2010 (as described on point 3 above) selected the various control and safety system components, in such a way as to guarantee a reliability level suitable to the actual severity of the hazard. To this purpose, the prescriptions of the following Harmonized Standard have been followed: EN ISO 13849-1:2015. Where the severity of the hazard is high (3 or 4 according to the classification of EN 12100:2010 Standard), the countermeasures adopted are carefully evaluated in order to guarantee the necessary safety margins, through redundancy or over sizing principles.

The **ROJ** machines ⁽¹⁾ respect the limits of Electromagnetic Immunity and Emission defined by the harmonized standard EN ISO 14982: 2009 for industrial environments

The **ROJ** User and Maintenance Manuals contain the updated list of the harmonized standards applied during the design stage to guarantee the compliance with the Essential Safety Requirement Listed on Annex I of 2006/42/EC Directive, while the design and implementation details are described on the Technical File kept by the manufacturer according to the prescriptions of Machinery Directive 2006/42/EC.

(1) *The term "Machine" used within this manual refers generically to the definition given in 2006/42/EC Directive and thus combines both complete machines able to carry out a well-defined function and "Partly completed machinery" or equipment or drive systems not able to perform a defined function as they are intended to be incorporated in a complete Machine.*

CE Identification Plate

The ROJ PCS PCS W1 kits are CE marked on the back side of the PCS AP. The CE marking refers to the whole PCS W1 kit.

Compliance with the Directives and European Regulations

Herein under a summary of the Declaration of Incorporation, prepared in accordance with the requirements of Annex II B to the 2006/42/EC Directive, with which **ROJ** declares that the following “Partly completed machinery”:

Type:	PCS W1
Manufacturing year:	See Official Declaration of Incorporation
Serial Number:	See Official Declaration of Incorporation
Target use:	servo-assisted drive of Seed Drills machines

can not be commissioned until the agricultural machine in which it will be incorporated will be declared compliant with the provisions of 2006/42/EC Directive - Annex II A - relating to Safety of Machinery, by the agricultural machine manufacturer or by system integrator and that for its design and manufacturing the principles and concepts introduced by the applicable paragraphs of the following Harmonized Standards were adopted:

- EN ISO 12100:2010
- EN ISO 13849-1:2015
- EN ISO 4254-1:2015
- EN ISO 14982: 2009
- EN ISO13849-2:2012
- EN 14018:2010

The equipment complies with the requirements of the following additional directives:
2014/30/UE Directive ^{Note 1} relating to Electromagnetic Compatibility.
2014/53/EU relating to Radio Equipment Directive

The person authorized to collect the Technical File is:
Ing. Luca Bagatin (luca.bagatin@roj.com)

The EHSRs (Essential Health and Safety Requirements) listed on Annex I of Machinery Directive 2006/42/EC met by **ROJ** are as follows:

1.1.1 – 1.1.2 – 1.1.3 – 1.1.6 – 1.2.1 – 1.2.2 – 1.2.3 – 1.2.4 – 1.2.6 – 1.3.2 – 1.3.7 – 1.3.8 – 1.5.5 – 1.5.6 – 1.5.11 – 1.6.1 – 1.6.3 – 1.6.4 – 1.7.1 – 1.7.2 – 1.7.3 – 1.7.4

The compliance with applicable EHSRs not included in the above list, shall be provided by the agricultural machine manufacturer or by system integrator.

In response to a reasoned request by the national authorities, ROJ is committed to send via e-mail or ftp relevant information on the partly completed machinery PCS 200.



The above indications are merely indicative and shall not be considered as an “alias” of the actual Conformity Declaration signed and released by the Manufacturer.

Note 1: The previous directive 2004/108/EC is repealed as from 04/20/2016

Warranty and Responsibility of the Manufacturer

The **PCS W1** system described in this manual is designed to be incorporated into agricultural machines and it's therefore destined to work exclusively in combination with the above machines.

The installation of the various system components on the Seed Drill can be performed:

- by the Seed Drill manufacturer
- by specialized personnel authorized by **ROJ**

The test and commissioning of the system is in any case entrusted to specialized personnel.

ROJ rejects any responsibility in case of system installation not compliant with the assembly instructions provided in this manual or in case of system commissioning carried out without the **ROJ** authorization.

The end user must ensure that the equipment is used in accordance with the law and rules in force in the country of installation, in particular for what concerns the safety of workers and, more generally, with regard to the requirements for health, safety and accident prevention.

Possible claims must be notified promptly upon detection of any defect attributable to the **PCS W1** system components.

If, after a careful evaluation, the validity of the complaint is recognized, **ROJ** may, at its sole discretion, replace or repair the defective parts.

Other warranty terms

ROJ guarantees the quality and reliability of the equipment that has been designed and manufactured to provide optimal performance.

The warranty does not cover any damages or indirect costs due to machine downtime, or irregular operation caused by improper use of the equipment or of individual **ROJ** devices.

It is the responsibility of the end user to periodically perform cleaning and ordinary preventive maintenance activities, aimed at maintaining the equipment operation within the expected performance range.

The warranty expires in case of equipment failure due to improper connections.

The warranty does not apply in case of floods, fire, electrostatic/inductive discharges or in case of discharges caused by lightning or other phenomena external to the **ROJ** equipment.

The warranty does not cover possible damage to operators or other equipment/devices connected to **ROJ** equipment.

The customer is responsible for the proper use and proper maintenance of the equipment, according to the instructions provided in this operating manual.

Parts subject to normal wear are not covered by warranty.

Any other warranty form is excluded.

1.1 INTRODUCTION

1.1.1 The ideal solution for control and optimization for distributor control

The PCS W1 Kit is designed to be installed on agricultural machines, such as hoppers and seed metering devices in order to control and optimize the distribution process.

Thanks to its exclusive simplicity and easy to use characteristics, the PCS W1 Kit is the ideal solution to motorize fertilizers spreaders and have an easy way to control them from the tractor cabin.

1.1.2 Manual objectives

This manual has been prepared to supply the users of PCS W1 Kit with the essential information required to:

- Correctly install and connect the system components in safety conditions.
- Configure the system and program the various operation parameters according to the end-user needs.
- Perform ordinary preventive maintenance of the system in safety conditions.

1.1.3 How to Use this Manual

The manual is subdivided into four sections:

- Section 1** – explains the structure and the system components and contains the notes and warnings for safety, in addition to the technical data of the units that constitute the kit.
- Section 2** – describes the operations and procedures required for a correct installation and commissioning of the system.
- Section 3** – describes the machine operator interface, the configuration modes, the parameters setting and the information for a correct interpretation of alarm messages and faults.
- Section 4** – contains the information and warnings necessary for the proper maintenance of the system.

1.1.4 Symbols used

+ Highlights notes, warnings and subjects to which the attention of the reader should be directed.



It indicates a particularly critical situation, which could affect either the user safety or the correct system operation.



It indicates the obligation to dispose of the environment impact material, in compliance with the local regulations.



It indicates the activities executed through a simple but essential visual inspection.

1.1.5 Environment protection



Handling of electrical or electronic equipment at the end of the life cycle (Applicable to all countries of the European Union and to those countries where a separate collection of waste is in force).

This symbol shown on the product or on packaging indicates that the product itself shall not be considered as normal house-waste, but rather that it must be delivered to an appropriate collection point, for recycling of electrical and electronic equipment. Making sure that this product will be correctly disposed of, you will contribute to prevent potential negative effects to the environment and to the health, which otherwise could be caused by a non-adequate disposal. For more details about the recycling of this product, you may contact your municipal technical office, your local waste disposal service or your dealer.



The exhausted batteries must be correctly recycled into appropriate containers. DO NOT DISPERSE THE BATTERY IN THE ENVIRONMENT.

1.2 GENERAL INFORMATION AND PERFORMANCES

1.2.1 Introduction

The PCS W1 system is designed to be applied to agricultural machineries such simple hopper of fertilizer spreaders or grain metering devices, in order to replace the mechanical transmission that drives the metering units with electrical motors, that can be controlled by a smartphone or a tablet.

The basic functions of the system can be summarized as follows:

- **Control of the fertilizer and micro-granular distributor speed** to distribute a predefined mass per hectare of sown field
- **Hectare counter** in order to track the work area
- **Distributor quantity estimation** in or

1.2.2 Functional blocks (Ref. Fig. 1-1)

The system consists of the following functional blocks:

- **MD**: one motor with integrated drive, used for driving the fertilizer and micro-granular distribution device.
- **AP**: a wi-fi module which that allows the connection to the system with a smartphone/tablet, creating a dedicated wi-fi network.
- **Machine position sensor**, to determine if the Seed Drill is raised (transport/manoeuvring position) or lowered (sowing position).
- **Speed sensor**: wheel sensor that generates an incremental position reference (or speed) of the tractor.
- **ISO-11786 cable (optional)**: to be used as alternative the speed sensor and machine position sensor and receive the information from the ISO-11786 plug of the tractor.
- **Wiring** for connection of the various devices and to receive power from ISO-12369 plug of the tractor.

1.2.3 Acronyms used

EHSR Essential Health and Safety Requirement of Annex I of Machinery Directive

PL Performance Level (level of reliability of the safety functions) according to EN 13849-1

AD Analog/Digital Converter

CAN Controller Area Network (BUS)

AP Access point

MD Motor with integrated drive

1.3 COMPONENTS OF THE PCS W1 KIT

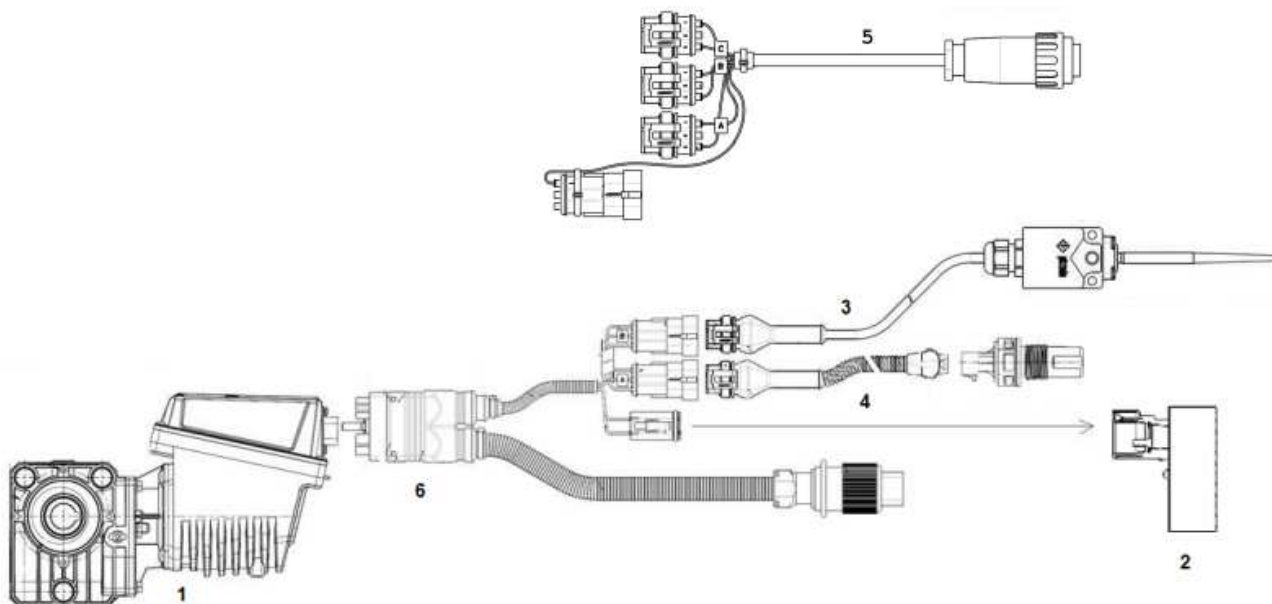

Figure 1-1 Main components of the PCS W1 Kit

TECHNICAL DATA

1	MD	Rated voltage: 12 VDC; Rated current: 6,6 A; Rated power: 80 W Rated speed: 100 rpm
2	AP	Rugged access point module Rated voltage: 12-24 VDC; Rated current: 250 mA;
3	Machine position	Machine position sensor (implement switch)
4	Speed sensor	Hall effect speed wheel sensor
5	ISO-11786 cable	Alternative to 3 and 4, can be used to receive speed and hitch position information directly from tractor
6	Wiring	Wiring for connection of the various devices and to receive power from ISO-12369 plug of the tractor.

1.4 GENERAL SAFETY INFORMATION

1.4.1 Design Criteria

The principles introduced by the relevant paragraphs of the following Harmonized Standards have been adopted in the design and manufacturing of the PCS W1 kit:

EN ISO 12100: 2010	Safety of machinery - General principles for design - Risk assessment and risk reduction.
ISO 13849-1:2015	Safety of machinery - Safety-related parts of control systems - Part 1: General principles for design.
EN ISO13849-2:2012	Safety of machinery - Safety-related parts of control systems - Part 2: Validation.
EN ISO 4254-1:2015	Agricultural machinery - Safety - Part 1: General requirements
EN ISO 14982: 2009	Agricultural and forestry machinery - Electromagnetic compatibility - Test methods and acceptance criteria
EN 62311: 2009	Assessment of Electronic and Electrical Equipment Related to Human Exposure Restrictions for Electromagnetic Fields (0 Hz-300 GHz) (EN 62311:2008 Identical, IEC 62311:2007).
62368-1:2014:	Audio/video, information and communication technology equipment - Part 1: Safety requirements

The compliance with the applicable paragraphs of the above listed standards allowed us to eliminate or reduce risks in the best possible way, during normal operation and during maintenance and/or adjustment tasks, for the entire life cycle of the machine.

All components have been carefully selected among those available on the market, and the materials used in manufacturing the system present no risk to the health and safety of persons.

In addition, for the PCS W1 system the safety measures aimed at eliminating or reducing within acceptable limits the residual risks, have been implemented (see paragraph "warning information about the Residual Risks").

In particular, the Essential Health and Safety Requirements of Annex I to Directive 2006/42/EC listed in the Incorporation Declaration have been respected.

The respect of non-listed requirements must be assured by the by the system integrator and shall be confirmed during the commissioning of the PCS W1 system.

1.4.2 Safety Devices and Solutions

All moving parts of the gearmotors are adequately protected to prevent mechanical hazards and the parts of the driving device electrically powered are enclosed in casing with minimum protection degree IP65.

On the guards of seeding units a safety device (electromechanical microswitch or electromagnetic sensor) is installed that prevents the gearmotor start in case of guard open.

This safety measure is not foreseen for the fertilizers and micro-granular distribution units, since the guard open condition does not involve exposure to hazards for the operator.



Access to components of the integrated drive inside the gearmotor can be carried out only using suitable tools and can be exclusively carried out by skilled and authorized staff, with machine stationary and disconnected from power sources.

Any attempt to remove or by-pass the safety measures installed, thus reducing the overall safety level, IS FORBIDDEN.

The responsibility for consequent damages to people and/or properties resulting from the non-fulfilment of recommendations will entirely fall upon the user.

1.4.3 Warning About Residual Risks

Notwithstanding all the safety measures taken and listed in the previous paragraph, some risks remain during installation, use and maintenance due to:

- the presence of electricity even in conditions of agricultural machine stationary
- the presence of potential high temperatures in the gearmotors units

During these stages you must then proceed with utmost care to avoid dangerous situations.

The presence of these residual risks is indicated by special warning labels attached to the containers of the gearmotor built-in drives.



It indicates the need to pay due attention to avoid the risk of burns.

1.4.4 Warning and Rules of Behaviour for the Operator

To avoid any dangerous condition for the operator or damages to equipment, we advise you to scrupulously follow the warnings and the rules of behaviour listed below.

✚ **ROJ will assume no liability for possible damage to people and/or properties deriving from non-observance of these warnings.**

- ❖ Operators shall be properly trained to use the equipment without risk, and must have read and understood the instructions and warnings given in this manual.
- ❖ Personnel performing installation and maintenance of the machine must read this manual before performing any electrical or mechanical intervention.
- ❖ Operators must wear appropriate clothing, avoiding or paying attention to:
 - fluttering clothes
 - necklaces, bracelets and rings
 - wide sleeves
 - long hair
 - hanging ties or scarves
- ❖ Before using the machine equipped with PCS W1 System ensure that any dangerous condition for safety has been appropriately eliminated, that all guards or other protective devices are properly installed and that all safety devices are efficient.
- ❖ Do not start the machine in case of anomalies.



DO NOT attempt to remove or by-pass any of the safety measures: doing so will reduce the safety level of the system.

DO NOT perform any type of work with machine powered.



At the end of every maintenance work, ensure that no used tool remained near the gearmotors.



Prior to startup the machine, restore and always check the correct functioning of the safety devices, if they have been de-activated during the operation.



All environmentally hazardous materials to be eliminated after a maintenance work carried out on the equipment (such as electrical cables, components, etc.) must be disposed of in conformity with current laws.

1.4.5 Noise Levels

The PCS W1 system have been designed and manufactured to reduce the noise to minimum levels during operation.
In any case, since the only potential noise sources introduced by the PCS W1 system (*gearmotors*) are negligible (<70 dBA) with respect to the noise produced by agricultural machine as a whole, the determination of the weighted sound pressure level generated by the whole machine is the responsibility of the manufacturer of the machine itself and/or of the end user.

1.4.6 Radio frequency related information

The PCS W1 contains a wireless CAN-to-WiFi module, the PCS W1 AP (54T00991R). This device is a radio device with the following characteristics:

Communication protocol:	802.11b, 802.11g, 802.11n (Wi-Fi)
Operational Band:	2.412 – 2.472 GHz
RF power:	17 dBm

1.4.7 Proper and Improper Use

The PCS W1 system is designed to be incorporated in agricultural machines.
The PCS W1 use for different purposes, can cause injuries or damages to the machine itself and it is considered **Improper Use**, which the Manufacturer cannot be responsible for.

1.4.8 Safety and reliability of control systems

On this equipment, the safety control systems have been implemented according to the principles of the Harmonized Norm EN ISO 13849-1:2015. The following table shows the values of Category and of Performance Level (PL) implemented (with respect to the Required Performance Level (PLr) resulting from the risk assessment).

The PL calculation has been carried out by means of the "SISTEMA" (IFA) software.

Safety function	Category	PL	PLr
Inhibition of dangerous movements in case of metering unit guard open	1	c	c

The calculation of the PL values and the "SISTEMA" relevant report can be found in the Technical Documentation kept by the manufacturer.

2 - INSTALLATION

2.1 GEARED MOTOR CHARACTERISTICS (PCS MD-O)

For more information, please refer to the following documents enclosed:

- *TD_1406.601_revD.pdf or later revision.*
- *1061_hard.pdf*
- *1061-cid-a.pdf*
- *1061_angle.pdf*

2.1.1 Outlet shaft torque and speed

The following characteristics refer to the variables of the geared motor outlet shaft (slow shaft)

Nominal torque	8.75Nm
Peak torque	19Nm (single pulse, duration 500ms) 12Nm (repeated, duration 500ms, every 5 seconds)
Nominal speed	100 rpm

The application must have the torque and speed requirements compliant with such indications.

For more information, please refer to *TD_1406.601_revD.pdf* or later revision.

2.1.2 Outlet shaft dimensions

The geared motor outlet has a hollow shaft with the following dimensions.

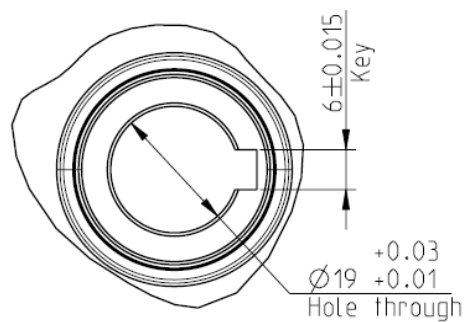

Figure 2-1 – Outlet shaft dimensions

For more information, please refer to *1061-cid-a.pdf*

2.1.3 Fastening flange characteristics

Please refer to [1061-cid-a.pdf](#)

2.2 MOTOR INSTALLATION (PCS MD-O)

2.2.1 General principles

The fastening of motors to the machine, whether they are used for the seeding disc shaft or the fertilizer or micro-granular distributor shaft rotation, must be carried out in order to ensure a perfectly aligned coupling between the disk/distributor shaft and the reducer outlet hollow shaft.



In the absence of a perfect alignment, radial forces may occur on the bearings, causing an increase of the necessary torques and a reduction of the device life.

In order to relieve the bearing stress, an elastic coupling can be used. This one is not supplied with the motor kit and it must be chosen and dimensioned according to the application.

2.2.2 Mounting angle limits

The gearbox must operate with the axis parallel to the horizontal plane.

In order to ensure the correct lubrication of the reduction stage, do not exceed the maximum angles indicated on the following figure.

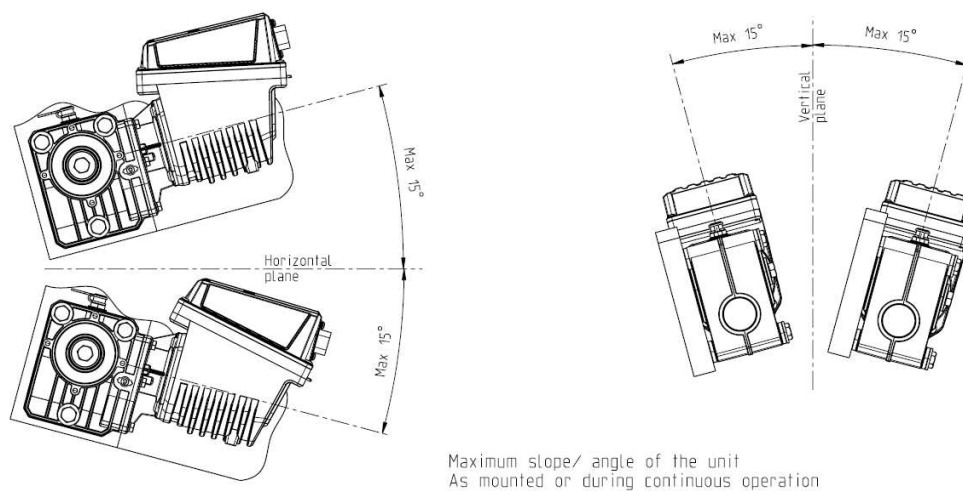

Figure 2-2 – Mounting angle limits

For more information, please refer to [1061-angle.pdf](#)

2.2.3 Transport cap

The motor is delivered with the oil filling cap, with the rubber part positioned, in order to avoid lubricant leakages during the transport stage. This part must be removed only during the installation stage.

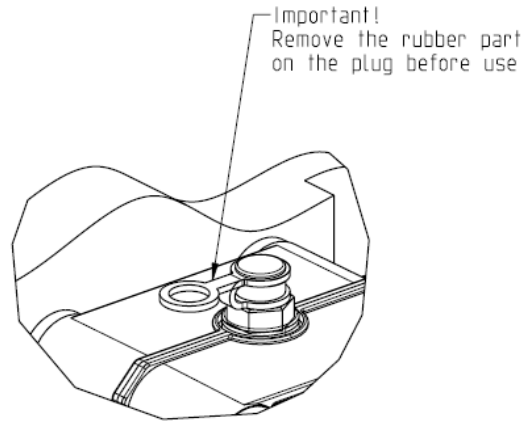

Figure 2-3 – Cap with vent

2.2.4 Fastening

Six special aluminium bushes are provided for the correct motor fastening. The motor must be fastened to the flange, using the bushes, bolts M8x80 and standard M8 washers, as indicated on the following figure. It is suggested to lock the bolts with a thread-lock product.

Tightening torque: 10 Nm.

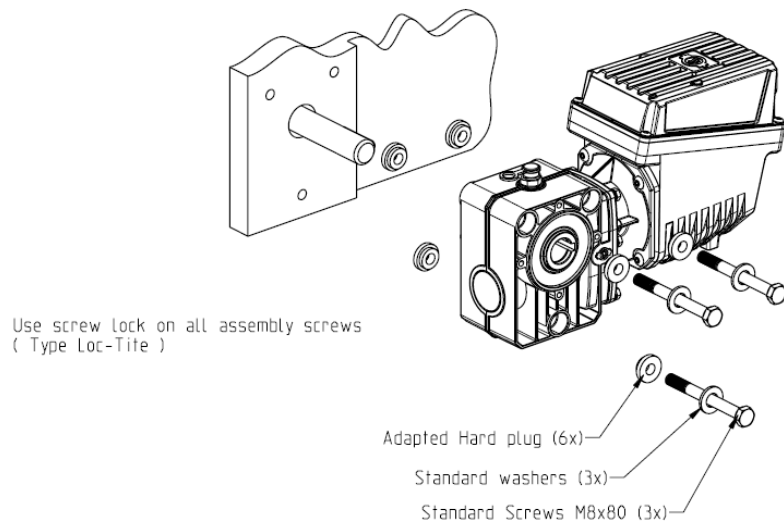

Figure 2-4 – Details for the motor fastening

2.3 SPEED SENSOR

2.3.1 Cogwheel individual sensor

The speed sensor is implemented using a hall effect speed sensor type Cherry GS102301 (P/N ROJ 50A00174R) and relevant cable (P/N ROJ 05R01400).

The sensor detects the speed of a toothed wheel connected to a machine drive wheel.

+ *We recommend the toothed wheel to have at least 25 pulses per revolution.*

The sensor must be connected to the wiring connector indicated with SPEED.

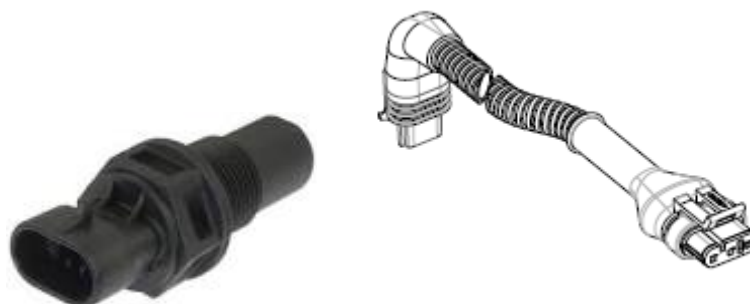

Figure 2-5 – Speed sensor and relevant cable

The phonic wheel is not provided with the kit, because the maximum dimensions as well as the number and shape of the teeth and the connection to the wheel depend on the type of machine and on the available space.

The following figure represents an example of cogwheel used for the suggested sensor.

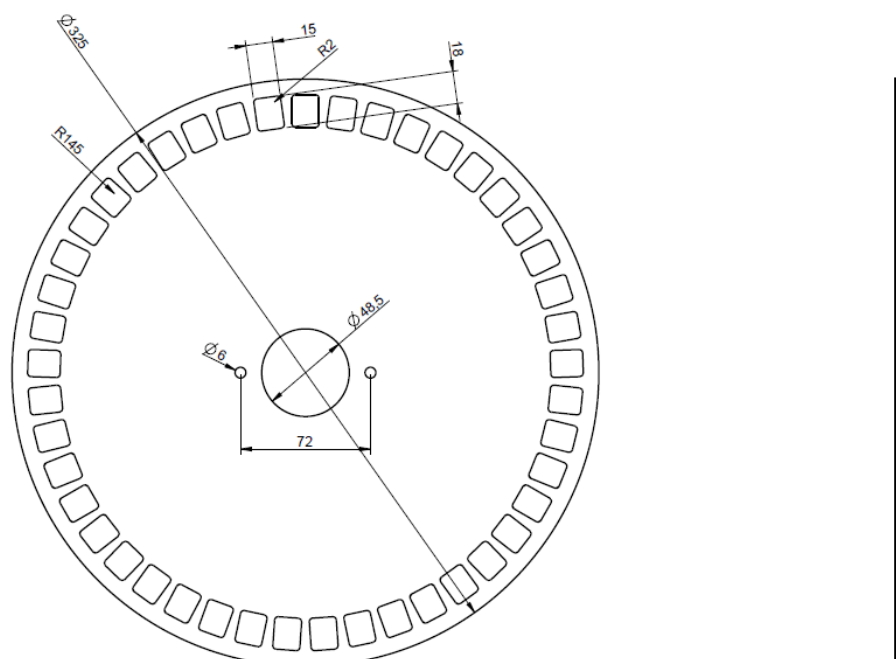

Figure 2-6 – Example of phonic wheel for speed sensor

The cogwheel must be fastened directly to the seed drill drive wheel, i.e. avoiding idler gears with chains and pinions.

During the installation stage, correctly adjust the sensor/teeth distance, in such a way as to guarantee the correct count.

During the machine overall operation check, you can confirm the correct operation carrying out the following procedure.

From our experience the minimum number of the tooth of the phonic wheel is 25.

Example:

Considered a tractor wheel with diameter of 64cm, with 25 pulses per turn of the sensor wheel this generate 1191 pulses in 100 meter. This is a good resolution.

2.3.2 Tractor speed

Is possible to use the speed and machine signals from the tractor with special cable 05R01423 directly connected to ISO tractor plug.

This connection allow tree different signal from the tractor:

- Speed RADAR (A): RADAR on the tractor or RADAR emulation from the GPS
- Speed IN (B): Directly from cog
- Machine position (C): Up and Down machine

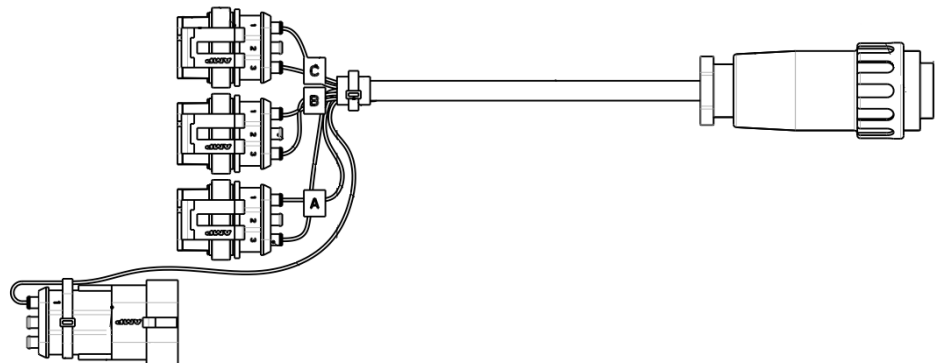

If one of the connector are not used, close it with the appropriate connector.

2.4 MACHINE POSITION SENSOR

It is an mechanical proximity sensor (P/N ROJ 05R01422) used to define whether the machine is in seeding position (machine lowered) or in transfer position (machine raised).

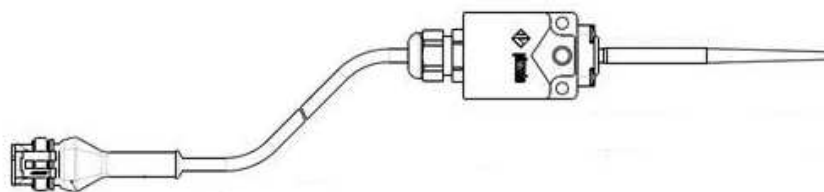

Figure 2-7 – Position sensor

The sensor must be fastened to the machine frame, in such a way that:

- in seeding position, i.e. with machine lowered, the sensor is de-activated
- in transfer position, i.e. with machine raised, the sensor is activated

The sensor must be connected to the wiring connector indicated with PROXY_MACHINE.

During the machine overall operation check, you can confirm the correct operation carrying out the following procedure.

2.4.1 Position sensor check

On the graphic display main page (see paragraph 3.3.1), check the tractor icon with in both conditions:

- **Sensor de-activated:** tractor icon representing the machine in working position (green).
- **Sensor active:** tractor icon representing the machine in transport position (red).

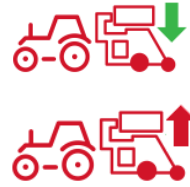

2.5 AP POSITIONING

The housing of the AP control unit must preferably be installed in a sheltered position of the machine, with cable output facing downwards.

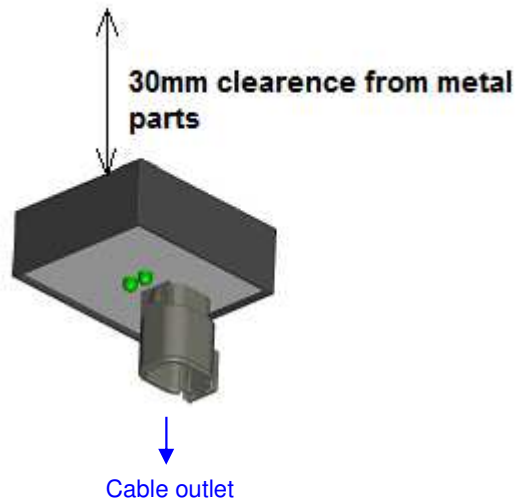

Figure 2-8 – AP positioning



Connector must be connected to the faceplate in order to avoid the entry of water and dust.

- + *The box contains the WiFi module and antenna. Install the box so that the flat back surface has a 30mm clearance from metal parts. Violating this precaution will degrade the antenna efficiency, resulting in a reduced or impaired functioning of the AP.*

2.6 ELECTRICAL CONNECTION DIAGRAM

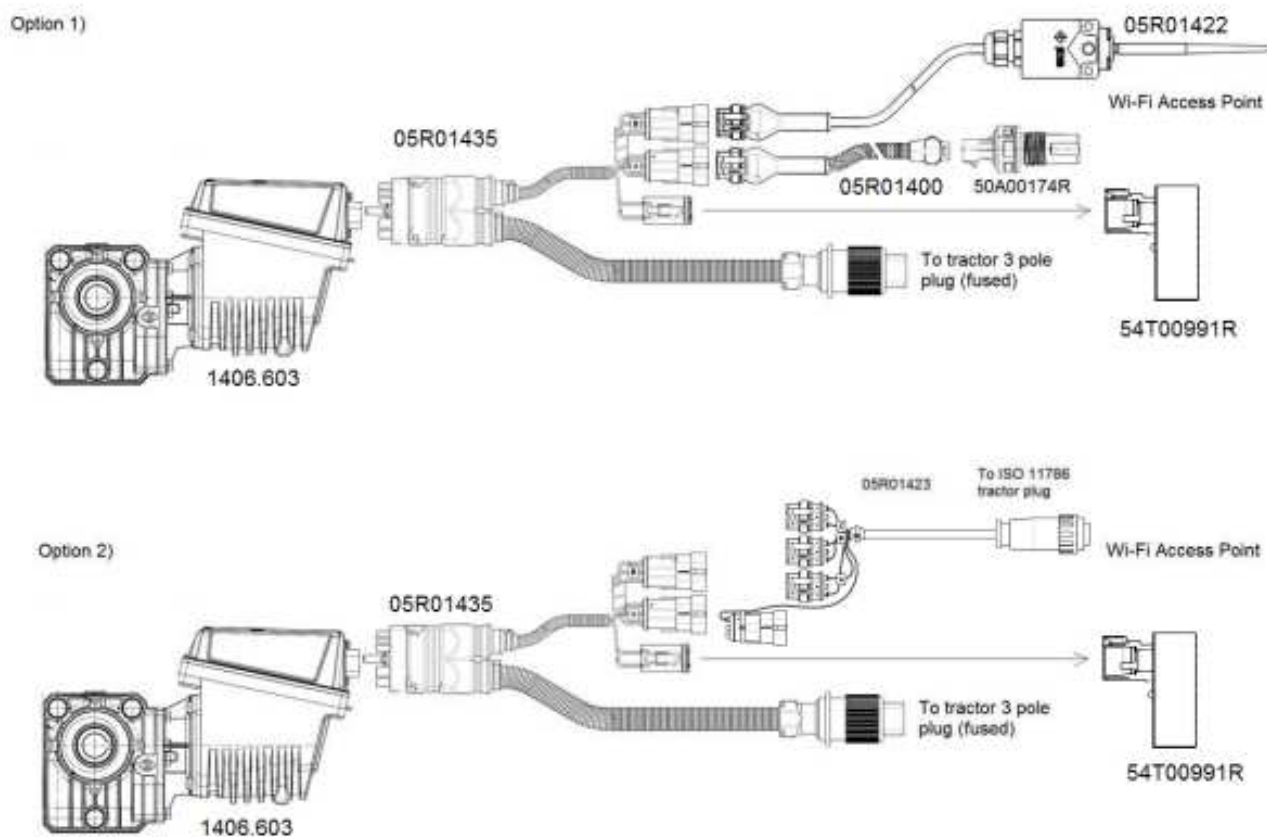

Figure 2-9 – System connection diagram

+ Codes of the various items are indicated on the following pages.

2.6.1 Main components

Code	Description
1406.603	PCS MD-O W1
54T00991R	PCS W1 AP
05R01422	MACHINE POSITION SENSOR
05R01400	GS102301 SPEED SENSOR CABLE L=2000mm
50A00174R	HALL EFFECT SPEED SENSOR GS102301 + NUT
05R01435	MD CABLE - PCS W1 (6 POLES)
05R01423	SIGNAL CABLE-ISO11786 DMD

2.6.2 MD connection

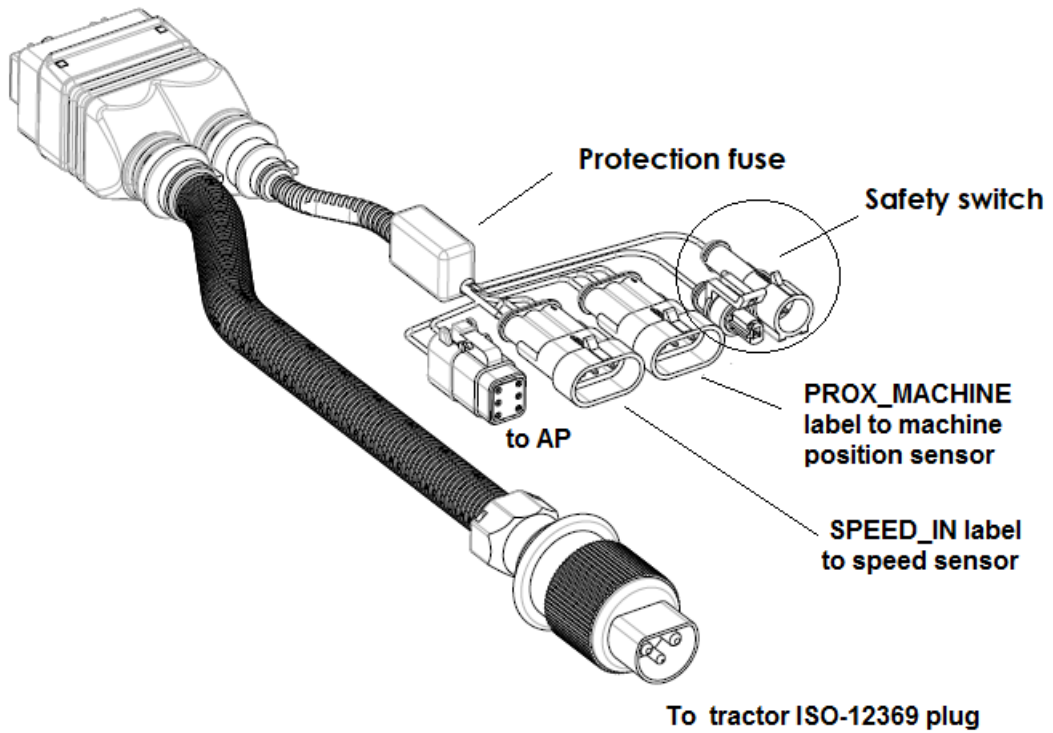



Figure 2-10 – MD connection diagram

2.6.3 Safety switch

The connection to the safety if the contact is open, the MD cannot rotate.
The safety switch must be implemented using:

- an electro-mechanical switch with “positive opening” NC contact (condition indicated by the symbol )
 - or
 - an electromagnetic sensor with high reliability (e.g. SICK RE11-SA03 or equivalent)
- +
- In order to ensure the requested safety level (Performance Level = c – see paragraph 1.4.7), it is necessary to provide a safety contact with the following characteristics:*
- $B10d \geq 2 \times 10^6$ (see note below)
- +
- The safety switch is not provided with the kit, because the choice depends on the size limits of the machine on which it will be installed.*

Note: B10d is the reliability parameter declared by the device Manufacturer that corresponds to the number of switching operations guaranteed without errors.

2.6.4 Tractor plug

- + The power cable 05R01435 shall be connected to a ISO-12369 on the tractor. See below a picture of the tractor side plug.

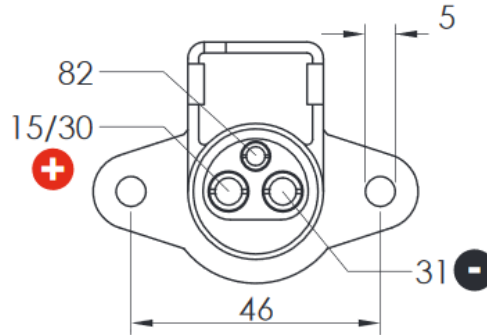

- + In case the plug is not available, the following optional cable can be ordered, which can be used to connected directly to battery to create an extension and includes the protection fuse.

Code	Description
05R01412	CAVO BAT - ISO12369

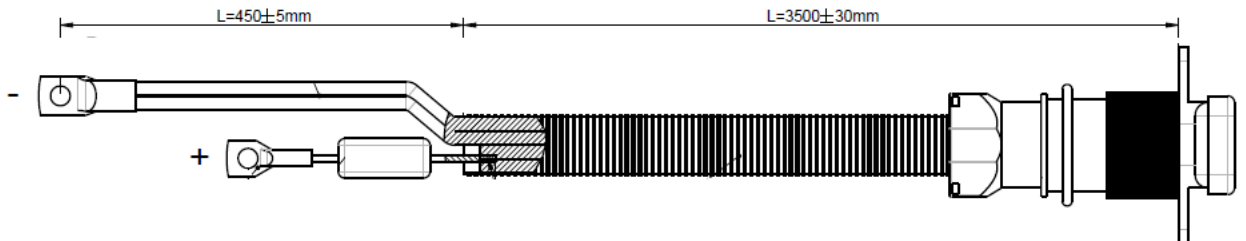

2.6.5 Fuse on 05R01435 cable



To fulfil the safety norms, the cable 05R01435 includes a protection fuse ATO 1A (black). This fuse protects the supply of the access point (AP) and the supply to the sensors.

3.1 GENERAL DESCRIPTION

The PCS W1 kit can be controlled by an app (iOS or Andoid). Make sure to download the latest app from Apple Store or Google Play Store, searching for **PCS W1**.

The app allows to monitor and set-up some system parameters by means of a smartphone or a tablet, using a WiFi connection.

3.2 CONNECTION TO ACCESS POINT

In order to connect the portable device to module, turn on the WiFi interface and scan the network; the module present itself as an Access Point with default SSID **ROJDMDWIFI** and default password is **rojdmwifi**.

The default SSID and Password can be changed from the Configuration page. (see chapter 3.4)

When the connection is up, launch the app on your mobile device.

Led Blue:

When the AP is ON an the Wifi network is active, the blue led on the PCS W1 AP will turn ON.

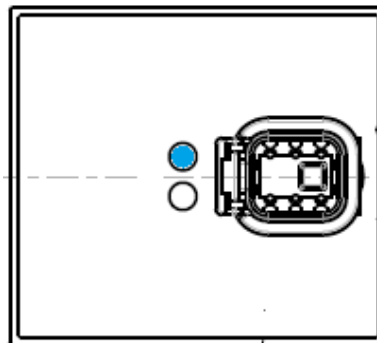

Led Orange:

To start with the application functionality press chain button in the center of "Main"

page  → 

In this condition led orange turn on.

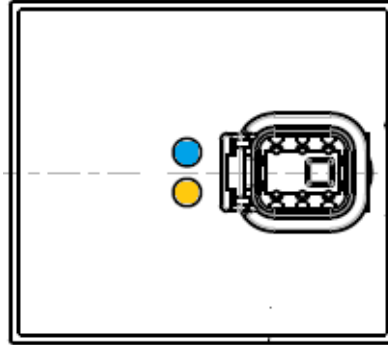

3.3 MAIN PAGE

The picture below shows the main web app page. In the following paragraph the different functions will be described.











+ *Note that the appearance of the main screen can differ, depending on the motor SW version. See chapter 5.0 for details.*

3.3.1 Connection and configuration buttons

The picture below shows the main web app page and highlights the main controls.







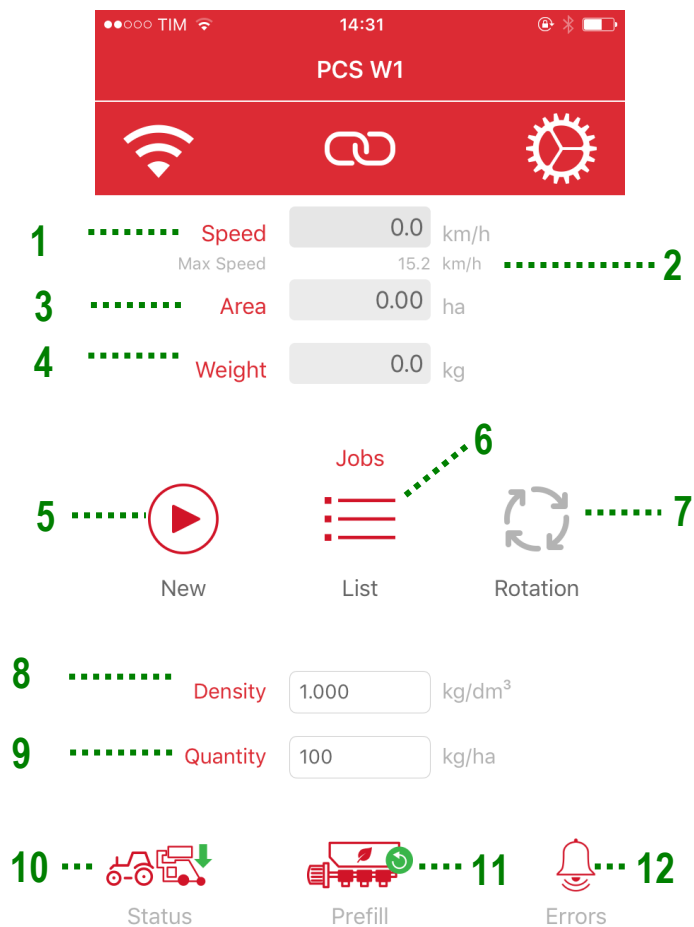

Field	Function	Description
1	WiFi connection status	 Connection OK  (blinking) Connection Poor  Connection Lost
2	CAN bus connection status	 CAN Connection Lost or disconnected. If pressed, connects the AP to the motor.  (blinking) CAN Connection Poor  CAN Connection OK If pressed, disconnects the AP from the motor.
3	Link to the configuration page	 press on this icon to open the configuration page









+ Note: to connect to the AP to the motor, press the CAN, press the  button. When can connection is active, the yellow led on the PCS W1 AP will turn ON.

3.3.2 Job information and settings



Field	Function	Description
1	Speed	Tractor Seed [km/h]
2	Max speed	Maximum seeding speed allowed with this settings
3	Area	Partial Hectar counter. Reset  by pressing
4	Weight	Provide and estimate the amount of released product. Reset  by pressing
5	Start/Stop Job	 Starts a new job and resets all counters.  Stops and stores job counters.
6	Job list	Opens job window (see chapter3.8)
7	Rotation ¹	 grayed steady icon = motor is NOT rotating  red rotating icon = motor is rotating
8	Density	Range [0,2-2 kg/dm ³] Product density per hectare, configurable by the user.
9	Quantity	Range [1-1000 kg/ha] Product quantity per hectare. Configurable by the user.

¹ This icon is not available with all motor firmware version. Check chapter 5.0 for more details.

<p>10</p>	<p>Seeding machine position</p>	 <p>Seeding machine raised (transport position)</p>  <p>Seeding machine lowered (working position)</p>
<p>11</p>	<p>Motor status</p>	 <p>OK. If pressed, prefill starts</p>  <p>OK. Prefill on going...</p>  <p>OK. Normal working status</p>  <p>Manually excluded</p>  <p>Error</p>
<p>12</p>	<p>Error button</p>	 <p>No error active</p>  <p>Alarm active. If pressed, opens the alarm list. (see chapter 3.3.3)</p>

+ Note that the hopper will distribute the product even if the  button hasn't been pressed. The  and  buttons control the start and the end of the job recording that will be stored in the job log (see chapter 3.7)

3.3.3 Errors and Error List

When an error occurs, a pop-up will appear, warning the user of the error situation. Pressing OK will acknowledge the situation and close the pop-up.

Note that if the error situation persists, the error will remain active and will be shown in the Error icon.

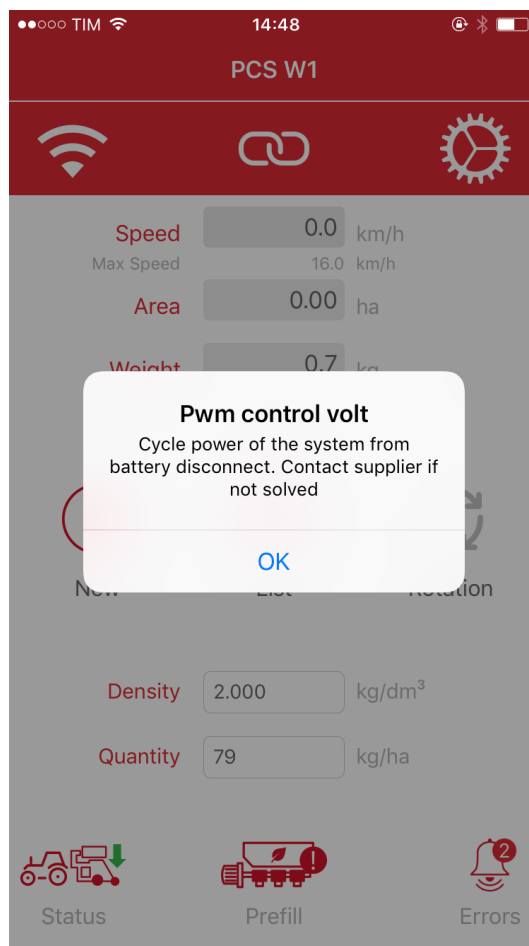

If Alarm are present and the Alarm button is pressed



, an alarm list section is opened as shown in the picture below.

Field	Function	Description
1	Alarm List table	Table containing all active alarm together with a suggested solution

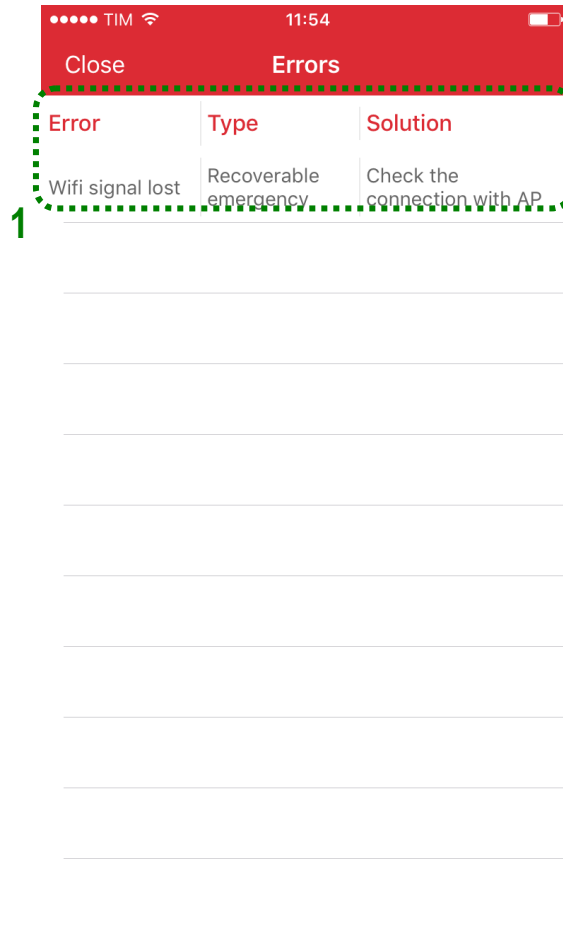

3.4 CONFIGURATION PAGE

The configuration page can be entered by pressing the  button. It contains a number of field used to configure the behaviour of the system.

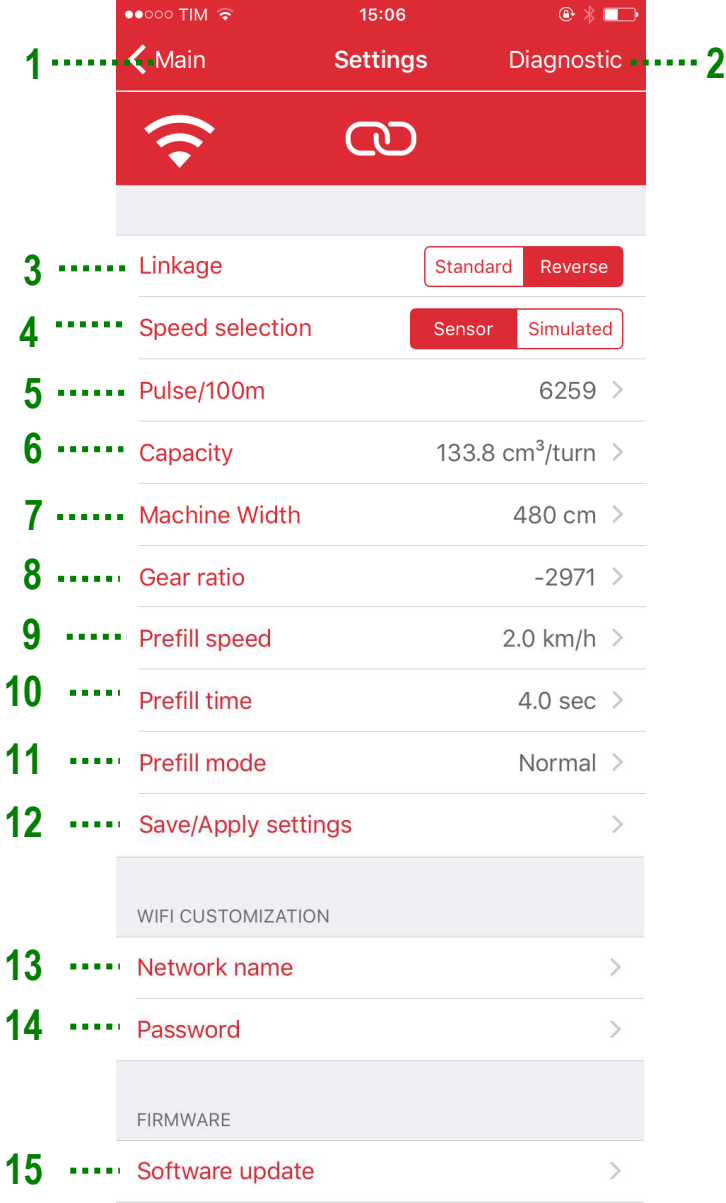

Field	Function	Description
1	Back	If pressed, go back to the main page
2	Diagnostic ²	Enters the Diagnostic page (see Chapter 3.10)
3	Linkage sensor	Defines the activity level of implement switch on linkage: <ul style="list-style-type: none"> Reverse: switch open → machine in working position Standard (e.g. ISO 11786 cable): switch open → machine in transport position
4	Speed selection ²	<p><i>Sensor</i>: input from physical sensor</p> <p><i>Simulated</i>: tractor speed is simulated internally, by using the value selected for Prefill speed (see below , item 9 e.g. if Prefill speed value is chosen to be 5km/h, than by selecting “Simulated”, the PCS W1 will simulate a working speed of 5km/h).</p> <p>This feature is useful in case of faulty speed sensors to be able to continue to work.</p> <p> Note that if <i>Simulated</i> is chosen, at power on is necessary to lift the machine in transport position and put it back to working position to activate the simulated speed.</p>
5	pulse/100m	Number of pulses per 100m. It is possible to change the value manually or following the calibration procedure. See chapter 3.5

² This icon is not available with all motor firmware version. Check chapter 5.0 for more details

6	Capacity	<p>Distributor wheel capacity, expressed in cm^3/turn.</p> <p>It is possible to change the value manually or following the calibration procedure, (see chapter 3.6) or apply a pre-saved setting (see chapter 3.9)</p>
7	Machine Width	Working width of machine [m]
8	Gear ratio	<p>Gearbox ratio multiplied by 100 (example: gear ratio 29.71 \rightarrow 2971)</p> <p>The minus sign indicates the direction of rotation opposite to the standard one.</p> <p>The default value, i.e. the ratio of the internal gear is 2971.</p> <p>If an addition external gear is uses, it has to be multiplied (example and external reduction 3.2:1 is added after the motor gear, the resulting gear ratio will be $3.2 \times 29.71 = 95.07 \rightarrow 9507$.</p>
9	Prefill speed	<p>The prefill speed determines the speed at which the motor turns during the prefill, during calibration and in case of simulated speed (see 4).</p> <p>Select a value which is close to the working speed of the tractor during the job.</p> <p>(e.g. if the tractor at cruise speed will drive at 6km/h, choose 6 km/h for this parameter as well).</p>
10	Prefill time	<p>When prefill is started by the user, the motor will turn at the cruise speed for a time equal to "Prefill time" seconds then it will start following the tractor</p> <p>The tractor must start driving slightly before the prefill time expires (see chapter 3.7 for explanation)</p>

11	Prefill mode ³	<i>No prefill:</i> prefill function <i>Normal:</i> see description at chapter 3.7 <i>Automatic:</i> see description at chapter 3.7, basically prefill is triggered at each transition from transport to working position
12	Save/apply settings	Allows to save current settings and recall them when necessary (see Chapter 3.9)
13	Network name	New name (SSID) for the wifi created by the PCS W1 AP.
14	password	New password for the Network.
15	Software update menu	Allows to update Access Point and MD firmware



Note that there is no means to reset the factory setting for the Network name and password, consequently be careful to take note of the new password when changing it, otherwise will not be possible to enter the access point anymore.

³ This icon is not available with all motor firmware version. Check chapter 5.0 for more details

3.5 Pulse/100 calibration

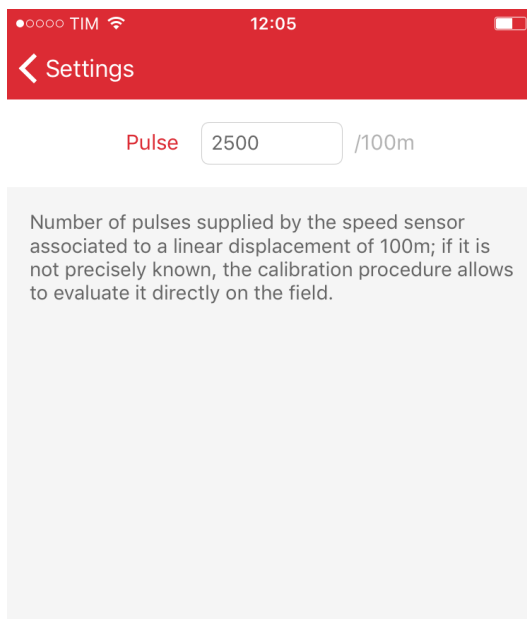

Calibration

Perform a linear displacement of 100m, then press
Stop

94



Once the start button is pressed, the user shall travel 100m and then stop. During the travelling, the wheel sensor will count the pulses and provide the correct number of pulses per 100m.

3.6 Capacity calibration

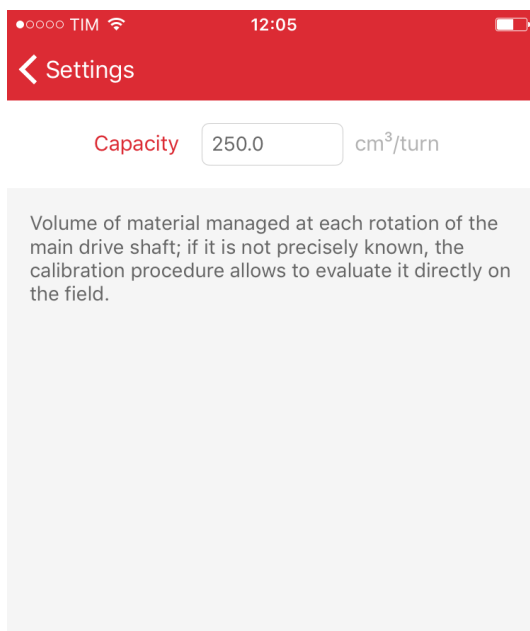

Calibration



Once the play button is pressed, the user is required to fill a container with the product. The container shall be large enough to contain 5-10kg of product.

Once the container is filled, the user can stop the rotation and insert the weight the amount of product in the container.

The app will automatically calculate the capacity per revolution of the metering wheel.

- + *Note that the calibration procedure is stopped automatically after 60s if the user doesn't stop it before.*

3.7 Prefill function

The prefill function can be used to have an anticipated start of the hopper, in order to make sure that the delivery tubes are filled with product before moving.

3.7.1 Prefill mode “No prefill”

If the Prefil Mode “No prefill” is selected, the prefill function is disabled.

3.7.2 Prefill mode “Normal”

If the Prefil Mode “Normal” is selected, the prefill will be executed as described in Figure 1:

If prefill button is pressed  the motor will start rotating at a constant speed as if the tractor has been moving at “Prefill Speed”, independently from the actual tractor speed, i.e. signal from speed sensor.

The motor will then start to follow the tractor speed after the “Prefill time” is expired.

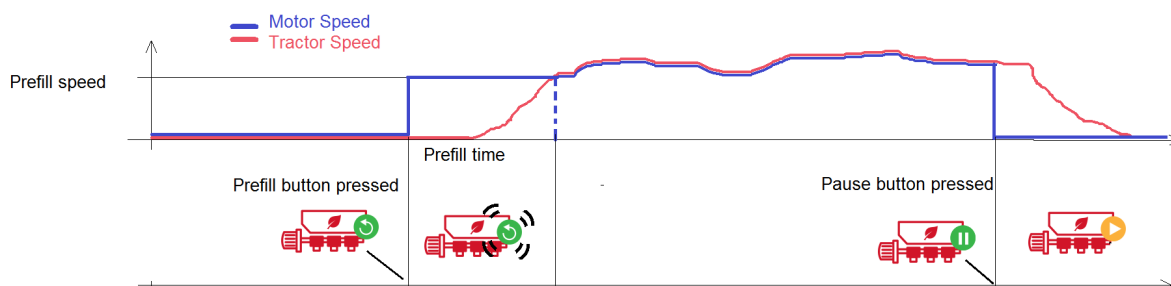



Figure 1 – Prefill function

+ Note that the prefill option  is enabled in the following ways:

1. at the **first power-up**
2. when the **following sequence is repeated at each end of the field:**

- Rotation is manually stopped, pressing the  button
- Machine is lifted and lowered back to work.

3.7.3 Prefill mode “Automatic”

If the Prefil Mode “Automatic” is selected, the prefill is executed automatically after each transition from transport position (machine lifted) to working position (machine

lowered), without the need to press the button 

Speed and duration of the prefill are respectively determined by “Prefill Speed” and “Prefill Time”.

3.8 Job List

The Jobs window allows to keep track of jobs
Each job correspond to a line on the table, which shows the summary of the job.

Start date	Area	Weight	
25/10/2016, 09:19	0.00 ha	0.1 kg	>
12/10/2016, 15:55	0.00 ha	5.1 kg	>
12/10/2016, 15:34	1.60 ha	566.7 kg	>
12/10/2016, 15:30	0.40 ha	151.7 kg	>
12/10/2016, 15:17	0.00 ha	16.1 kg	>
12/10/2016, 15:16	0.00 ha	7.2 kg	>
12/10/2016, 15:15	0.00 ha	3.3 kg	>
12/10/2016, 15:15	0.00 ha	0.5 kg	>
12/10/2016, 15:15	0.00 ha	0.4 kg	>

The following information are stored

- Start date
- Stop date
- Area covered
- Total (estimated) weight of distributed product

3.9 Save/Apply settings

The Save/Apply settings window allows store the current calibration relevant settings and recall them when necessary.

The calibration relevant parameters are:

- Capacity per turn
- Density of product
- Quantity of distributed product
- Prefill speed

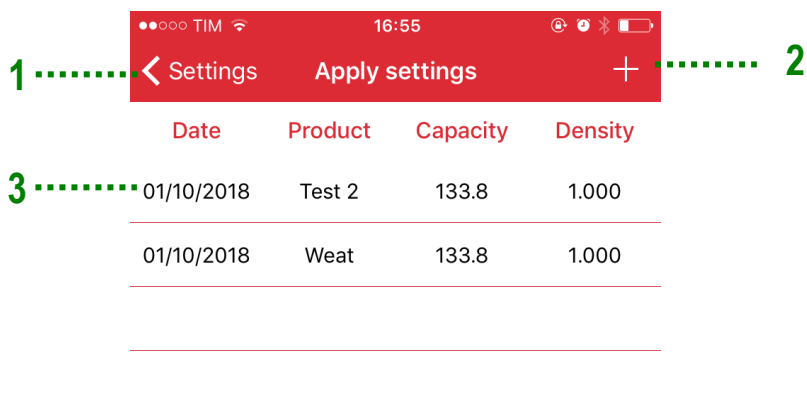

Field	Function	Description
1	Back	If pressed, go back to the main page
2	“+” button	<p>Adds a new row with the current settings. The operator is required to enter the name of the product / name of the settings.</p>

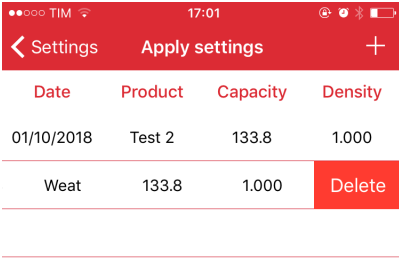
<p>3</p>	<p>Select/delete calibrations</p>	<p><i>Select:</i> Selecting the line, will open a windows with the summary of the relevant parameters that will be set.</p>  <p>Pressing "Apply" will load the selected settings into the PCS W1.</p> <p><i>Delete:</i> swiping a row will allow to delete it.</p> 
-----------------	-----------------------------------	--

3.10 Diagnostic page

The diagnostic page allows checking relevant parameters and it is very useful when checking the mechanical installation and for debug.

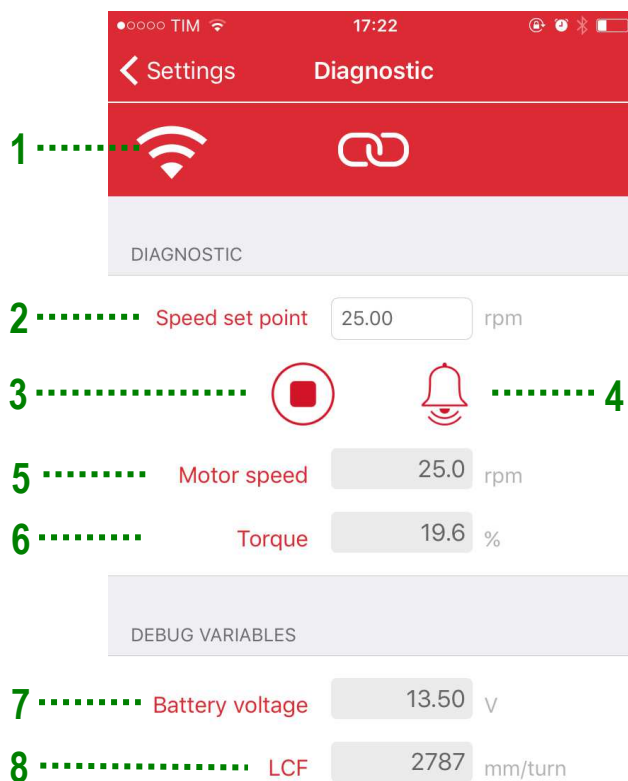

Field	Function	Description
1	Back	If pressed, go back to the setting page
2	Speed set point	Specify motor speed set point in rpm at distributor shaft (i.e. after the whole gearbox chain, as specified in the Gearbox Ratio field)
3	Play/Stop button	Start/stop the motor. When started, the motor will run at the set-point speed. If the specified motor speed is higher than nominal, the motor will self-limit itself to the maximum possible in the working conditions.
4	Error button	Same as the one in main page. See chapter 3.3.1 (item 12)
5	Motor Speed	Actual motor speed at distributor shaft (i.e. after the whole gearbox chain, as specified in the Gearbox Ratio field)

6	Torque	Motor torque as % of its nominal. E.g. 50% indicates that the motor is working at half its nominal torque
7	Battery voltage	Voltage measured at motor input [V]
8	LCF	Linear conversion factor (debug parameter)

4.0 ALARMS

The following chapter include a list of alarms/errors that can be generated by PCS W1 along with a possible solution to the error.

Code	Text	Solution
1	Overcurrent	Cycle power of the system from battery disconnect
2	Motor high temperature warning	Let motor cool down. Check mechanical arrangement to check that there aren't unwanted frictions, damage bearings, etc.
4	Safety switch open	Close safety switch on motor cable
8	Motor high temperature	Let motor cool down. Check mechanical arrangement to check that there aren't unwanted frictions, damage bearings, etc.
16	Blocked distributor	Check distributor of stuck/blocking product
32	High voltage	Check battery connection and fuses
64	Low voltage	Check battery connection and fuses
128	Low voltage warning	Check battery connection and fuses
256	PCB high temperature	Let motor cool down. Check mechanical arrangement to check that there aren't unwanted frictions, damage bearings, etc.
1024	Motor lock	Let motor cool down. Check mechanical arrangement to check that there aren't unwanted frictions, damage bearings, etc.
4096	Pwm control voltage	Cycle power of the system from battery disconnect. Contact supplier if not solved
16384	AP heart beat missing	Check AP cable connection. Check battery voltage
32768	PCB high temperature warning	Let motor cool down. Check mechanical arrangement to check that there aren't unwanted frictions, damage bearings, etc.

5.0 Compatibilities with different motor SW versions

The appearance of main screen, settings screen and the availability of diagnostic screen depends on the SW version of the motor (MD version), the version of the access point (PCS W1 version) and the app version.

- + *Make sure to download the latest app from Apple Store or Google Play Store, searching for **PCS W1**. The version of the app at the date of release of this manual is **1.1.2***

The following functions are conditioned on the SW versions:

- **Motor rotation** icon in main screen. In case this function is not available, the icon is not shown on the home screen.
- **Prefill mode** selector. In case this function is not available, the selector is not shown, and the prefill mode will be “normal”
- **0.01 accuracy of hectare counter**. In case this function is not available, the hectare counter will have an accuracy of 0.1 ha.
- **Diagnostic Screen**.
- **Speed Selection**. If not present, speed reference is taken from physical sensor.

5.1 Determine SW versions

To know SW versions of your system, follow the instruction below.

1. Go the setting page and select "Software update".

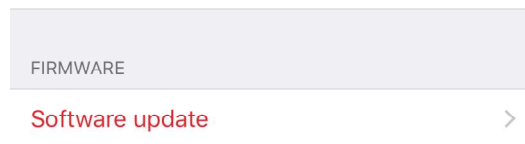

2. skip the instruction pages.
 - a. If you reach the following page, then you have a **first generation** of PCS W1.

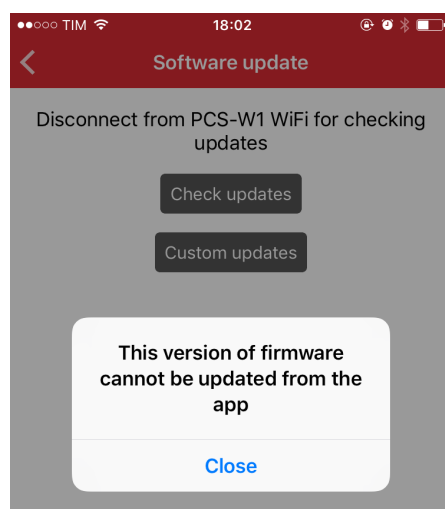



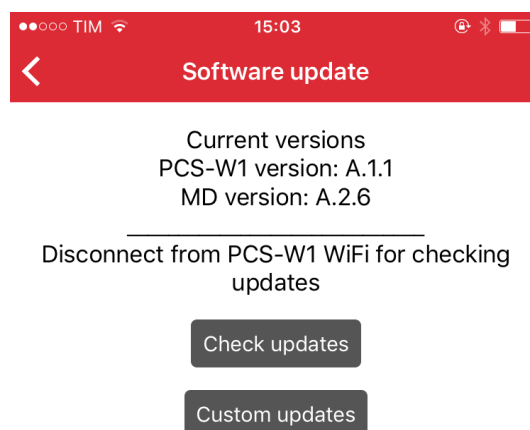







- b. If you reach the following page, then you can determine the version on the lines "PCS W1 versions" and "MD versions".



5.2 Compatibility table

The following table summarizes which features are available on the PCS W1, depending on the SW versions you own (see 5.1).

PCS W1 version	MD version	Feature				
		Speed selection	Diagnostic screen	Motor rotation icon	Prefill mode selector	0.01 ha counter accuracy
First generation		-	-	-	-	-
1.1	<A.2.2	-	-	-	-	-
	X.0.0				-	-
	>=A.2.2				-	-
	>=A.2.6					

+ Note that **first generation** PCS W1 versions or the one with MD version **X.0** can't be upgraded to support the features indicated above.

The other versions can be upgraded to support all features. Please contact your local dealer of ROJ's customer service (mechatronics@roj.com) for further details..

4 – MAINTENANCE AND TROUBLESHOOTING

4.1 GENERAL INSTRUCTIONS ABOUT MAINTENANCE WORKS

Thanks to its intrinsic sturdiness of the PCS W1 system components, heavy preventive maintenance works are not required. However, to guarantee high reliability levels and avoid hazard conditions, it is advisable to scrupulously read the instructions and warning listed hereunder.



For safety reasons, all maintenance works on the transmission devices must be carried out EXCLUSIVELY with machine stationary and disconnected from the electric power supply, by qualified and trained maintenance personnel having sufficient experience and knowledge of the PCS W1 system.



Prior to start the maintenance works, thoroughly clean the relevant zone. Do not use solvents!



All environmental impact materials that is necessary to eliminate as a result of maintenance operations (such as lubricants, dirty clothes, filter elements) must be disposed of according to applicable regulations.



Make sure that unauthorized personnel CANNOT have access to the working area during the maintenance activity. After the intervention, check that no tool used is left inside the equipment or electrical cabinet.

4.2 ORDINARY PREVENTIVE MAINTENANCE INTERVENTIONS IN CHARGE OF THE OPERATOR

Operation	Frequency	Notes
Cleaning	Before long periods of inactivity	If cleaning with a pressure washer, do not orient the jet directly to connectors and seals.
Tightening check	Every year, after long periods of inactivity (ex. at the beginning of the seeding season)	
Gearmotors replacing oil	Not necessary	

4.3 MAINTENANCE / REPAIR RESERVED TO SPECIALIZED PERSONNEL

Operation	Frequency	Notes
Check safety devices operation	At the beginning of each season	The check can be done by activating the motors, and verifying that when opening the safety contact of each MD, the motor stop its movement.

4.4 PARAMETER RANGE

PCSW1			
Range		Units	Commercial name
Min	Max		
-10000	10000	#	Gear ratio
800	500000	#	Pulse/100m
20	800	cm	Machine Width
0,2	2	kg/dm ³	Density
1	1000	kg/ha	Quantity
0,01	4000	cm ³ /turn	Capacity
0	20	sec	Prefill Time
0,036	32,4	km/h	Prefill Speed
0	100	rpm	Speed set point

4.4 SPARE PARTS

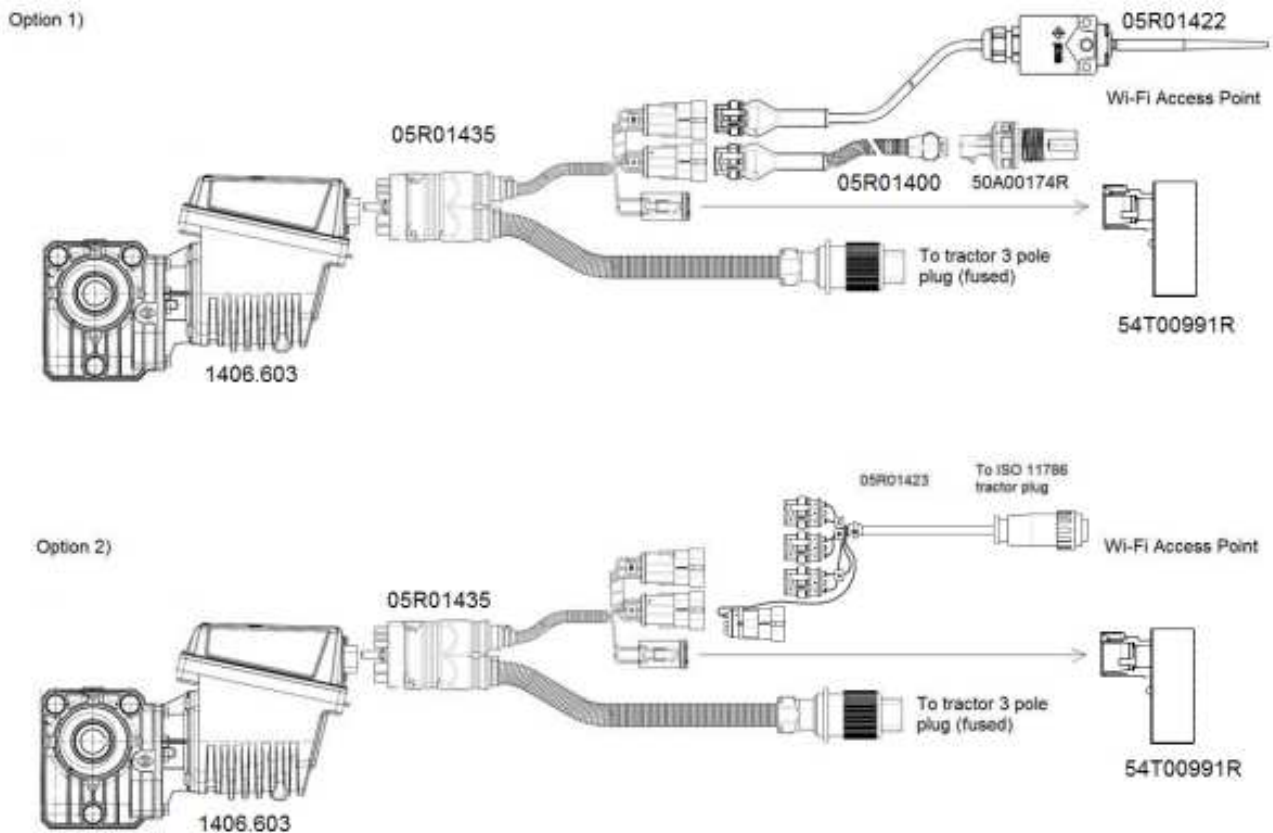

Figure 4-1 – Spare part chart

Code	Description
1406.603	PCS MD-O
54T00991R	PCS W1 AP
05R01422	MACHINE POSITION SENSOR
05R01400	GS102301 SPEED SENSOR CABLE L=2000mm
50A00174R	HALL EFFECT SPEED SENSOR GS102301 + NUT
05R01435	MD CABLE - PCS W1
05R01423	SIGNAL CABLE-ISO11786 DMD

Page intentionally left blank

DISTRIBUTOR

ROJ[®]

Via Vercellone 11
13900 Biella (BI)
Tel. +39 015 84 80 111
Fax +39 015 84 80 209
Email: comm@roj.com
www.roj.it

ISO 9001 Certificates by DNV from 1996
ISO 9001:2008 Certificates in 2009

REV. 1.6 E – 10/2018